



**An Introduction to the Flexographic Printing Plates
Environmental Footprint Calculator™
from
MacDermid Printing Solutions**

MacDermid Printing Solutions

April 26, 2010

Table of Contents

1	Executive Summary	1
2	Introduction	2
2.1	Purpose & Objectives	2
2.2	Methodology & Scope	2
2.3	Assumptions	4
2.4	Limitations	5
3	Photopolymer Printing Plates - Background	5
3.1	General Photopolymer Plate Parameters	6
3.2	Sheet photopolymer	6
3.3	Liquid photopolymer	11
4	Environmental Footprint Calculator™ - Capabilities and Features	14
4.1	Environmental Footprint Calculator™ Inputs	14
4.2	Environmental Footprint Calculator™ Outputs	14
5	Environmental Footprint Calculator™ - Comparison of Processing Technologies	17
5.1	Thick Plate, Digital Sheet-Solvent and Liquid Photopolymer	17
5.2	Thin Plate, Digital Sheet-Solvent and Digital Sheet- Thermal	21
5.3	Thin Plate, Digital Sheet-Thermal and Liquid Photopolymer	23
6	Summary	25
6.1	General	25
6.2	Future Work	25

1 EXECUTIVE SUMMARY

MacDermid Printing Solutions, working with The University of Tennessee Center for Clean Products and Ecoform consultants, has developed an Environmental Footprint Calculator™ that allows makers of flexographic plates to compare the environmental impacts of digital-solvent sheet photopolymer, digital-thermal sheet photopolymer, and liquid photopolymer platemaking options by plate thickness, size, quantity, and regional power grid. This tool allows the comparison of multiple technologies under locally relevant scenarios for the first time.

Our analyses of the environmental impacts of solvent, thermal, and liquid platemaking options found that environmental impact was highest for solvent processed digital sheet photopolymer plates, lower for thermally processed digital sheet photopolymer, and lowest for liquid photopolymer platemaking processes.

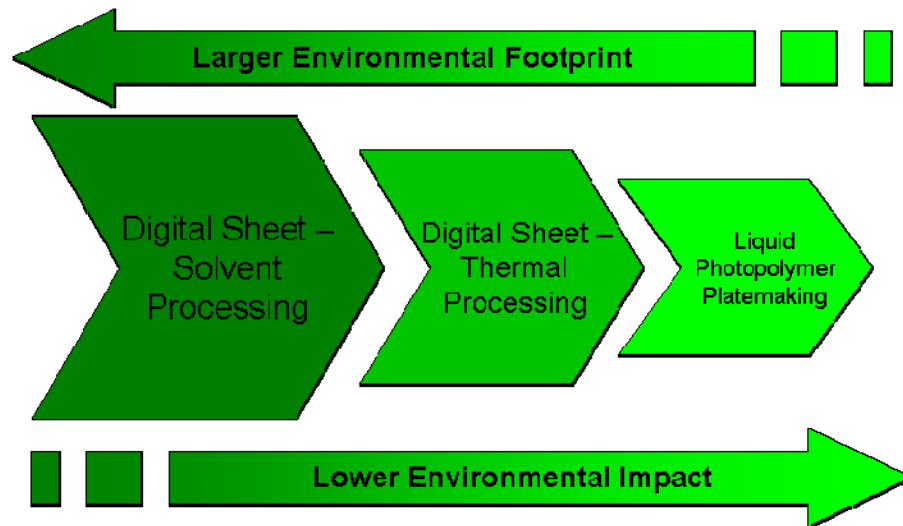

This relative ranking of photopolymer platemaking technologies held under all scenarios studied. The advantage for liquid was particularly pronounced for thick plates, where thermal processing is not currently practiced, and where the mass yield benefit of the liquid reclaim step gave a substantial advantage to liquid platemaking technology.

MacDermid Printing Solutions' LAVA thermal plate processing was found to have a lower environmental impact compared to solvent processing in all scenarios studied. Although solvent recycling has become an efficient industrial process over the years, the use of solvent inevitably expands the environmental impact of platemaking, simply by its presence.

The Environmental Footprint Calculator™ is a unique approach to the use and analysis of sustainability information in flexographic platemaking operations. It will enable flexographers to make more informed decisions as they evaluate their technology options. MacDermid Printing Solutions will be working with customers to explore all the analysis options offered by the Environmental Footprint Calculator™, and to further refine its accuracy and utility for the advancement of the flexographic printing industry.

2 INTRODUCTION

2.1 Purpose & Objectives

Sustainability is no longer a trivial consideration for any industry. Manufacturers of all sizes are being pushed by consumers, government agencies, and supply chain partners to communicate the environmental impacts of their products and to implement environmentally preferable practices. The package printing industry has a prominent and highly visible role to play in adopting sustainable manufacturing practices.

In response to the growing desire for more sustainable platemaking technologies, MacDermid Printing Solutions (MPS) partnered with The University of Tennessee Center for Clean Products¹ and Ecoform² to develop an interactive tool that characterizes the environmental impacts of MPS photopolymer manufacturing and processing technologies. The intention of the work was to go beyond a simple statement about the environmental impact of products and processes; the objective was to create a tool that allows platemakers to analyze multiple platemaking technologies and select the processes that best fit their unique combinations of technical requirements, process constraints, and environmental impact priorities.

In addition to the quantitative estimates of energy and materials consumed in each option, MPS wanted to present the results in more easily understood terms. To address this objective, the calculator developed in this work converts environmental impacts to parameters that are easy to visualize, such as an equivalent number of cars on the road. This makes the comparisons a bit more personally relevant and easy to grasp.

Lastly, the process mapping and measurement at the foundation of the analysis created an understanding of environmental impacts that is being incorporated into MPS research. The inclusion of environmental criteria into new product development processes has already begun, and is expected to improve the environmental profile of future MPS products and processes.

2.2 Methodology & Scope

The Life Cycle Assessment (LCA) methodology used in this study was derived from the United States Environmental Protection Agency (EPA) guidelines.³ This methodology is conceptually sound and has been the basis for many LCAs in the United States. As such, it was selected as the most rigorous means of ensuring a thorough study, and one that would support quantitative comparisons of different processes within our study and with other studies using the same methodology.

Because MPS set out to provide comparisons of processes which could be controlled or influenced by MPS, it chose to perform a 'cradle-to-gate' rather than a 'cradle-to-grave' analysis. Figure 1 shows the complete package printing supply chain, with the red box denoting the processes within the scope of our study. A full 'cradle-to-grave' analysis would include a number of operations that are only peripherally influenced by the choice of platemaking technology, and were thus declared 'out of scope' for this study. The printing and converting operations that occur after platemaking are highly energy and material-intensive, and if not set 'out of scope', might have dwarfed the environmental impacts of plate manufacture and imaging.

¹ <http://eerc.ra.utk.edu/ccpct/index.html>

² <http://www.ecoform.com/>

³ US EPA, "Life Cycle Assessment: Principles And Practice", Doc# EPA/600/R-06/060, May 2006. The methodology was documented under EPA contract no. 68-C02-067 by Scientific Applications International Corporation (SAIC).

The printing and converting industries have already conducted studies of many of these processes and are researching and advocating more sustainable practices through out the supply chain.⁴

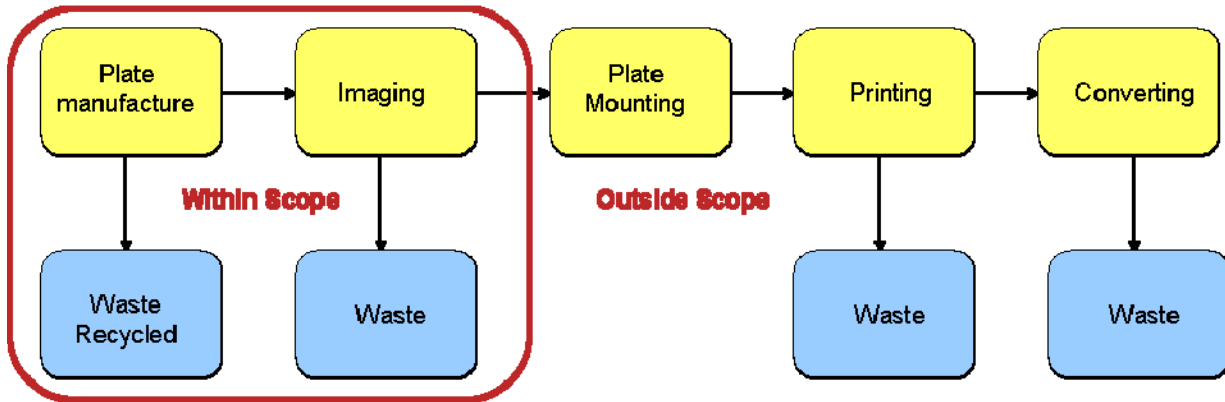

Figure 1: Cradle-to-Gate LCA Scope diagram

Thus, the scope of the Cradle-to-Gate LCA included the materials and energy usage associated with the following processes:

- Raw material manufacturing and processing
- MPS production and packaging of photopolymer material (sheet or liquid)
- Imaging and Processing of the photopolymer plate

For the purposes of comparison and scalability, all products were evaluated at the same functional unit. The functional unit is a standard measure of the products' use which will allow comparison of differing products. For this calculator, the functional unit was 1 ft² / 0.09 m² of photopolymer plate with an assumed 50% image density.

Transportation of the plates from MPS to customer sites was not included in the study, as it is highly variable based on distance and the method of transport. The impact of transportation stages in a life-cycle assessment are often very small compared to the production and use of the product, and would be similar for all the products compared, so this assumption did not alter the relative position of technologies in the final analysis.

A bill of raw materials (BOM), based on current MPS plate formulations, was assembled for each product type. In addition, all materials used as part of the plate processing methods (solvent, thermal, and liquid) were compiled. These lists are based on data collected by MPS personnel and represent production volumes and best practice platemaking scenarios. The BOM's were employed to model each product and product option in the life-cycle software GaBi version 4.3.⁵ Results from the simulations were then added to the Environmental Footprint Calculator™.

The GaBi 4.3 life-cycle modeling software databases, as well as the EcoInvent database, served as sources for the needed life-cycle data. All life-cycle data used were representative of

⁴ a) The Sustainable Green Printing Partnership, <https://www.sgpppartnership.org/>; b) RIT Sustainable Print Systems Laboratory, <http://sustainable.print.rit.edu/>

⁵ GaBi software from PE International, Leinfelden-Echterdingen, Germany, <http://www.gabi-software.com/gabi/gabi-4/>

industry averages and relevant regions. For instance, the liquid photopolymer and sheet photopolymer are manufactured at different locations. Thus, regionally appropriate energy grids were used to model each production process separately. The Environmental Footprint Calculator™ itself contains energy grid data for multiple power grids in the United States, Canada, and several European countries. These can be selected as part of the analysis process in order to understand the local power grid effects on plate processing environmental impact.

2.3 Assumptions

In any life-cycle assessment, assumptions are required for a number of reasons, such as the need to simplify operational details or a lack of available data. The assumptions made to construct the life-cycle models used in the calculator center on the production chemicals and the practices employed to create a plate are shown below. All assumptions are in keeping with industry standard practices for both life-cycle analyses and flexographic platemaking.

- The cut-off rule applied in this assessment was 1%. Any material on the Bill of Materials (BOM) for a product that did not account for at least 1% of the total mass of the product was excluded, with the remaining components normalized to reflect the actual mass of material used in a process.
- Due to limitations in available data describing the some of the specific chemical compounds used by MPS, limited chemical substitutions were made in the model. Every attempt was made to choose replacements that were synthesized in a manner similar to the actual raw material.
- A composite dataset was used to represent Digital CST, Digital Epic, Digital MAX, and Digital MVP as a 0.100" / 2.54 mm digital sheet plate. Results were then scaled to achieve estimates for other gauges by using the ratios of the gauges.
- A composite dataset was used to represent 0.250 inch / 6.35 mm gauge liquid photopolymer plates. Results were scaled to achieve estimates for other gauges.
- The bills of materials included manufacturing yields of 80% for photopolymer plates.
- A 50% imaged area was assumed for all plate types. Plate relief values modeled were consistent with industry standard practices.
- The calculator models the operations recommended to image MPS-manufactured sheet photopolymer as well as to produce and image MPS liquid photopolymer plates. Customers may deviate from these practices to various extents. Calculated results represent impacts associated with MPS-recommended operations only. Recycling of waste streams was estimated by using industry data on typical recycling rates for various materials. Details on recycling assumptions included:
 - MPS recommends to their customers that several items associated with MPS products be recycled, specifically the sheet plate coversheet and all packaging materials. Since it cannot be assumed that all customers indeed recycle - or recycle all of the suggested materials, this model based recycling rates on national averages reported by relevant trade associations.
 - Since life-cycle information for the recycling processes associated with the materials identified in this study was unavailable in some cases, and because often the most environmentally dominant aspect of recycling is energy consumption, a recycling process for each recycled material was created based on the amount of energy needed to produce the product from its raw materials.

2.4 Limitations

MPS contracted with the University of Tennessee Center for Clean Products and Ecoform in order to be certain that this study would be consistent with the highest standards of data collection and analysis in the LCA field. The methods, software, and material databases used in this study are the most current and extensive available today. It is, however, prudent to be aware of the limitations of the study.

- Results calculated by this model are influenced not only by data, but also by the assumptions made. These may have a significant effect on the values generated by the tool and must be considered when interpreting the results.
- Publicly available life-cycle databases are generally deficient in data describing chemical synthesis, in part due to the extensive number of substances that exist. It is therefore unsurprising that information describing some of the specific specialty chemicals used in MPS photopolymer products was unavailable. However, identification of synthesis ingredients (that are available in life-cycle databases) allowed for upstream impacts to be included.
- It is also important to remember that the values generated by this calculator represent only the life-cycle phases that were included in this study. This is a cradle-to-gate model, which means that impacts associated with the use and end-of-life of these plates were not evaluated. Comparison of the figures generated by the model to figures generated by other studies should be done with caution due to differences in photopolymer formulations, manufacturing processes, and platemaking equipment, as well as differences in assumptions and boundaries of the analysis.

3 **PHOTOPOLYMER PRINTING PLATES - BACKGROUND**

Flexographic printing plates are sold either as a solid plate (sheet) ready for imaging, or as a liquid photopolymer that is cast by the platemaker at the time of imaging. The choice between the two is a matter of economics, process time, intended printing application, and environmental trade-offs. The liquid photopolymer plate is typically less costly, quicker to produce, and generates little hazardous waste. Additionally, the uncrosslinked photopolymer remaining after imaging can be 'reclaimed' and used to form another plate, minimizing material waste. Sheet plates can attain a higher printing resolution, have broader ink compatibility, and require less expertise to image.

Although sheet and liquid plates are dissimilar at the molecular level, both are made of elastomers formed through UV-catalyzed photopolymerization processes. As might be expected for materials used in the same process, there are more things similar about the two plate types than there are different. As a result, there are many printing applications where either a sheet or a liquid plate may be used. In the past, decisions on which plate type to use were based on a number of factors, including precedent, existing process capabilities, price, and familiarity. With the MPS Environmental Footprint Calculator™, MPS adds a new consideration into the decision matrix for plate selection.

3.1 General Photopolymer Plate Parameters

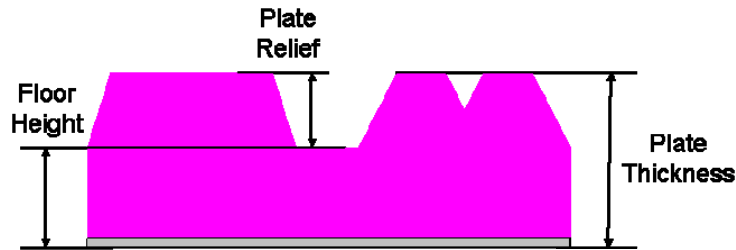

Figure 2: Imaged plate definitions, cross section

In both sheet and liquid photopolymer plates, the ready-to-print plate is described by parameters such as the total plate thickness (a.k.a. 'gauge'), the height of the relief image (plate relief), and the thickness of the photopolymer base layer (floor height), as shown in Figure 2 above. The area of the plate (i.e., its length and width) and the percentage of the plate area that is converted into a relief image (i.e., image density), shown in Figure 3, are also parameters that must be known in order to make a proper comparison of plates processed by different methods.

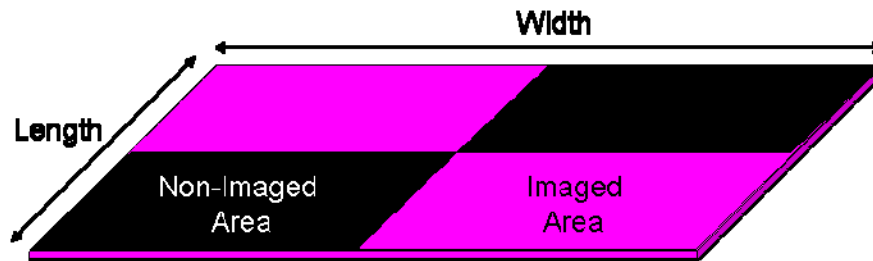

Figure 3: Imaged plate definitions, plane view

3.2 Sheet photopolymer

Sheet flexographic printing plates are available in a wide range of thicknesses (from 0.045 in to 0.250 in / 1.14 mm to 6.35 mm), hardnesses, and surface properties. Because there are few substrates that cannot be printed well using sheet photopolymer, it is a photopolymer format that has seen widespread adoption and use.

There are two different types imaging methods in common use today with sheet photopolymer - digital and analog. Analog imaging, which has been in use the longest, involves a plate constructed as shown in Figure 4. In use, the PET coversheet is removed and then a photographic (silver halide) negative film is placed on top of the slip film to provide the imaging mask needed for selective UV exposure and crosslinking of the photopolymer.

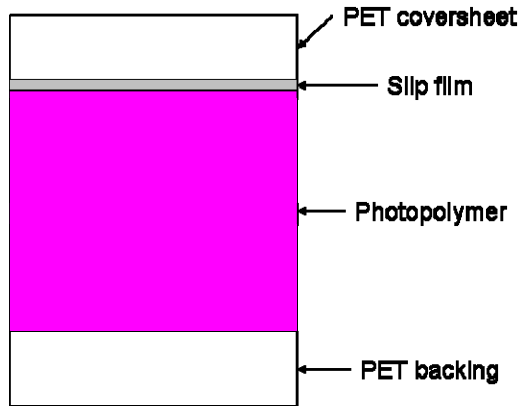

Figure 4: Analog sheet photopolymer construction (not to scale)

Digital sheet photopolymer has a 'digital mask' layer instead of a slip film (Figure 5). Rather than using a photographic negative film to provide the image mask, the digital mask layer is selectively ablated away using an IR laser to create an integral mask. This eliminates the use of a negative film altogether and provides a streamlined and fully digital workflow. In many cases, enhanced image quality is obtained as well.

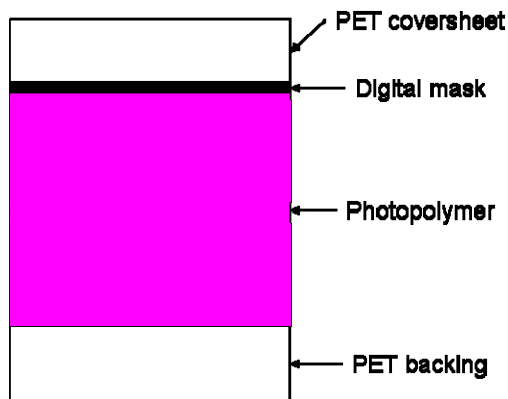

Figure 5: Digital sheet photopolymer construction (not to scale)

Although both imaging types are in common use today, the last ten years have seen widespread adoption of digital flexo platemaking throughout the industry, and it seems poised to command the greatest growth in flexo imaging technologies for the foreseeable future. For the purposes of this LCA analysis, a digital workflow and plate type was assumed. It seems likely that the environmental footprint of analog plates may be slightly higher than that of digital plates, simply because of the negative film, processing chemistry, and processing equipment required to create a negative. However, the difference in environmental impact alone is not expected to be large, nor does it seem to have been a major factor in the adoption of digital flexo plates.

3.2.1 Sheet plate manufacture

From a life-cycle perspective, there are two phases that need to be accounted for in the use of sheet photopolymer - manufacture and customer use. Manufacturing (Figure 6) inputs includes all the raw materials that go into the sheet plate, all the power and consumable materials used to run the manufacturing process, and all packaging in which the plates are shipped. Manufacturing outputs include the packaged plates ready for delivery to the customer plus any scrap waste generated by the process itself. The materials and process used for manufacture

are proprietary, so details of this process are not specified. However, the full material and energy impacts of the manufacturing process are incorporated in the life-cycle analysis.

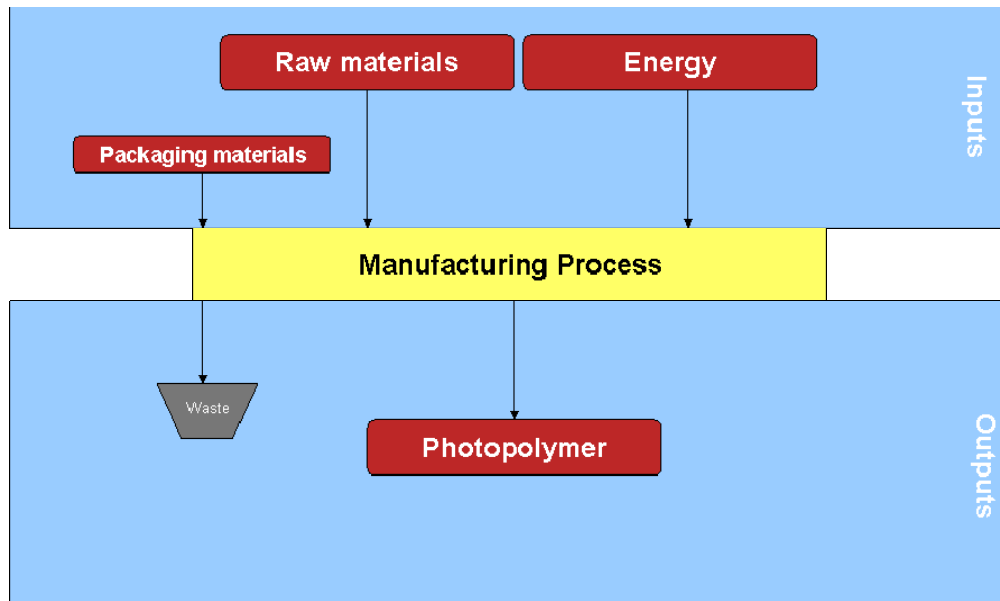

Figure 6: Sheet plate manufacturing process diagram

3.2.2 Sheet plate imaging and solvent processing

The second phase of the life-cycle of a sheet photopolymer plate is its use by a customer. This process includes imaging and processing of the sheet plate to create a relief image, or finished plate, that is ready for mounting and use on press.

MPS offers two options for processing of digital sheet photopolymer plates, solvent or thermal. Both options use the same plates, as most of MPS’ digital plates are ‘dual process capable’, meaning they can be processed by either method.

Plate Type	Solvent Process	Thermal Process
Digital MAX	✓	✓
Digital MVP	✓	✓
Digital CST	✓	✓

As Figure 7 (below) shows, the solvent process has the digital plate, clean solvent, and electrical energy as its main process inputs. However, it is also important to recognize that a significant proportion of the clean solvent used in the system is actually recycled solvent, since this is a common practice in ongoing operations. Depending on the size of the operation,

platemakers may choose to install a solvent recycling system in-house or contract with a recycling service that reclaims the solvent off-site. For the purposes of this study, assumptions included an in-house recycling scenario, a 90% recovery rate, and a distillation unit sized to closely match the maximum solvent consumption rate of the solvent processor.

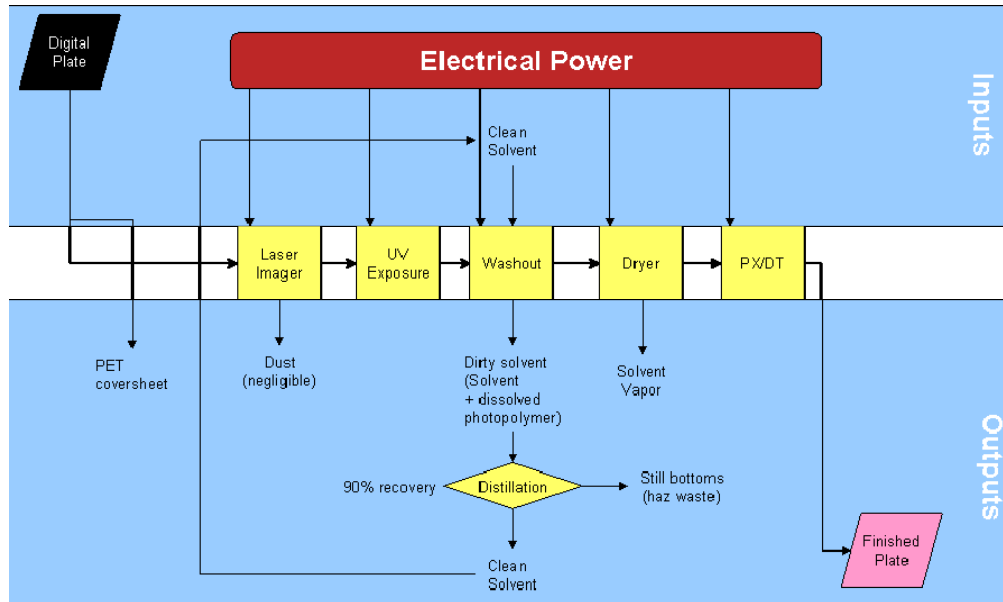

Figure 7: Sheet plate solvent processing diagram

Outputs of the process include the PET coversheet that is removed prior to laser imaging, a negligible amount of dust created during ablation of the digital mask, dirty solvent (reclaimed as described above), solvent vapor released during drying of the plate, and a finished plate. In addition, as a byproduct of the solvent recycling operation, still bottoms (typically a blend of photopolymer, solvent, and petroleum-based plasticizing oil added to help keep the mixture fluid) are produced and disposed of as waste. The still bottoms are often be used as input in a fuel blending operation and some energy value is thus recovered from this material.

The unit operations in solvent processing are:

1. Laser imaging of the digital mask;
2. UV (main) exposure;
3. Solvent washout;
4. Drying;
5. Post exposure and detack (PX/DT)

Each of these unit operations is powered electrically. Power consumption figures were directly measured on full size (maximum 50 x 80 inch plate size) equipment operating in the MacDermid Customer Demonstration Center (Atlanta, Georgia, USA). Total power consumption was summed either over a full eight hour production shift scenario (for continuously operating equipment like the dryer or still) or as the sum of multiple intermittent operating events during the same eight hour shift (for laser imager, UV exposure, washout, and PX/DT equipment). The production rate was modeled at 80% of maximum theoretical throughput, based on the rate-limiting unit operation, which is typically the laser imager.

3.2.3 Sheet plate imaging and thermal processing

The thermal plate processing sequence has the digital plate, a blotter material, and electrical energy as its process inputs (Figure 8). There is no solvent used in this process, rather the unpolymerized photopolymer that remains after UV exposure is removed by melting and then wicking away by a blotter material.

Outputs of the process include the PET coversheet that is removed prior to laser imaging, used blotter (containing unpolymerized photopolymer), and a finished plate. In addition, because a set of activated carbon filters are used to remove any organic vapors created during the thermal processing of the plate, these constitute an additional waste stream. However, because the filters typically are changed at a rate orders of magnitude lower than the blotter, this is a very small contributor to the overall waste stream and was thus ignored.

The unit operations in thermal processing are:

1. Laser imaging of the digital mask;
2. UV (main) exposure;
3. Thermal processing;
4. Post exposure and detack (PX/DT)

Three of the four unit operations are identical to those used for solvent processing, and again each of these unit operations is powered electrically. Power consumption figures were directly measured on full size (maximum 44 x 60 inch plate size) equipment operating in the MacDermid Customer Demonstration Center (Atlanta, Georgia, USA). Total power consumption was summed over a full eight hour production shift scenario as the sum of multiple intermittent operating events during the shift. The production rate was modeled at 80% of maximum theoretical throughput, based on the rate-limiting unit operation, which is typically the thermal processing unit.

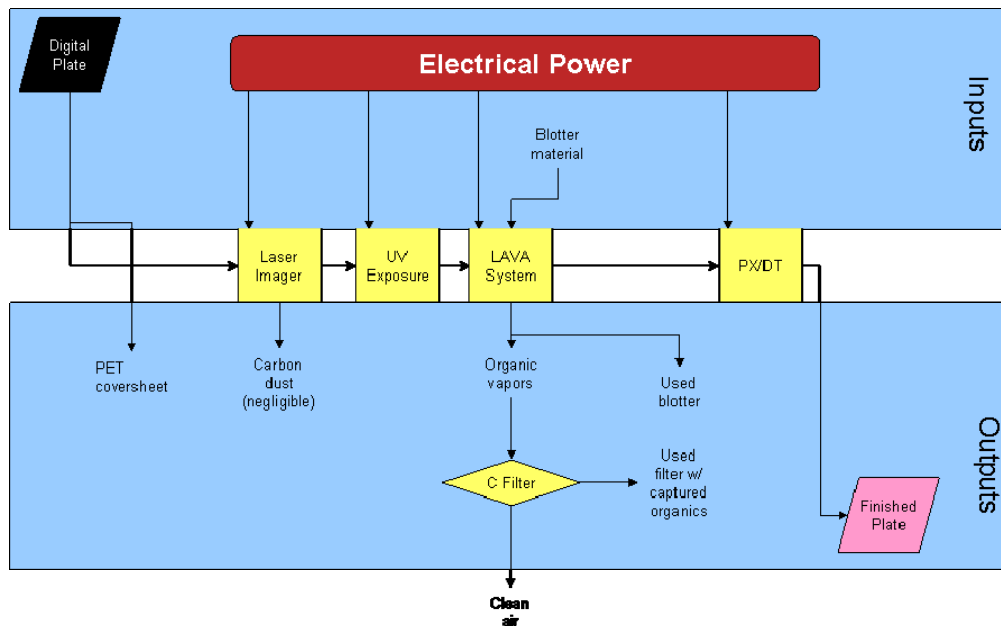

Figure 8: Sheet plate thermal processing diagram

3.3 Liquid photopolymer

Liquid photopolymer plates are used in a wide array of printing applications, and have a wide range of resolution capabilities and plate durometers. One limitation of liquid photopolymer plates is their moderate resistance to solvent-based and UV-curable inks. For this reason, virtually all of the printing done with liquid photopolymer-derived plates is water-based ink on paper-based substrates. Liquid photopolymer plates have long been popular in post print corrugated operations, and have also been widely exploited in multiwall bag and folding carton printing applications.

3.3.1 **Liquid photopolymer manufacturing**

Manufacturing (Figure 9) inputs includes all the raw materials that go into the liquid, all the power and consumable materials used to run the manufacturing process, and all packaging in which the liquid is shipped. Manufacturing outputs include the packaged photopolymer ready for delivery to the customer plus any scrap waste generated by the process itself. The materials and process used for liquid photopolymer manufacture are proprietary, so details of this process are not divulged. However, the full material and energy impacts of the manufacturing process are incorporated in the life-cycle analysis.

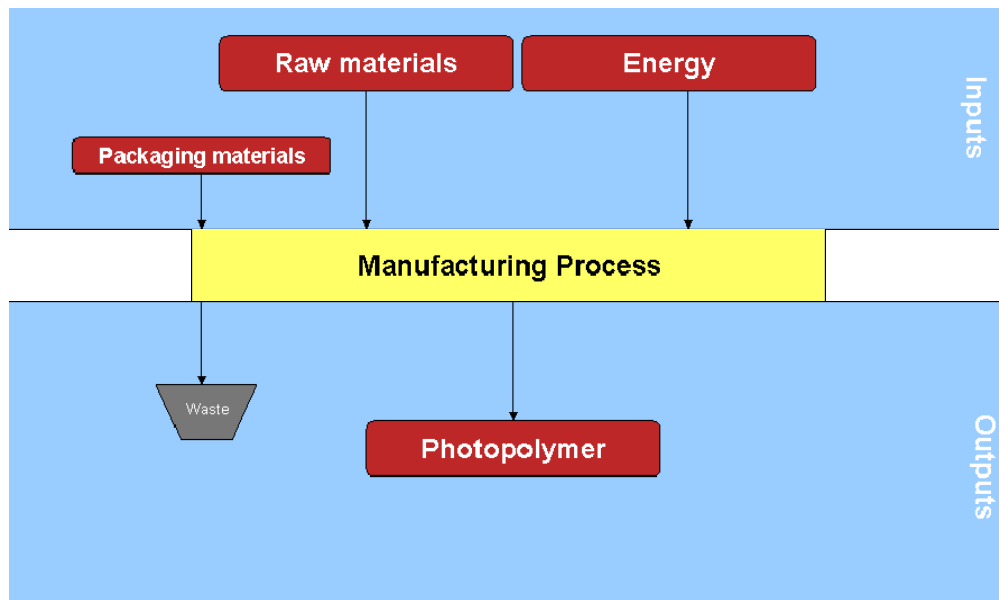

Figure 9: Liquid photopolymer manufacturing process diagram

3.3.2 **Liquid photopolymer platemaking and processing**

Liquid photopolymer is provided to the platemaker as a viscous liquid, and thus requires that the purchaser create the plate at the dimension of their specification. Production, or casting, of the plate and the imaging step occur simultaneously on a specialized piece of equipment. The sequence of layers in casting and imaging step is shown in Figure 10, showing that the plate is made 'upside down' compared to sheet plates.

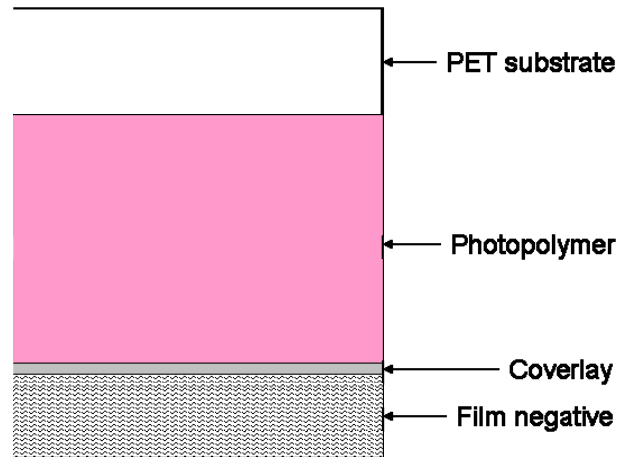

Figure 10: Liquid photopolymer platemaking layers diagram (not to scale)

The unit operations in liquid platemaking and processing are:

1. Casting of the plate;
2. UV (main) exposure;
3. Reclaim of unexposed photopolymer;
4. Washout & rinse;
5. Post exposure (PX) & rinse;
6. Drying;
7. Detack exposure (DT)

The overall liquid plate production sequence (Figure 11) begins in the casting & exposure unit by placing the film negative mask (made from silver halide-based photographic film) onto the casting surface. A thin protective film—referred to as the coverlay—is placed over the film and pulled down by vacuum. A precision-cast layer of liquid photopolymer is then applied on top of the negative-coverlay layer, immediately followed by the PET film which becomes the finished plate backing.

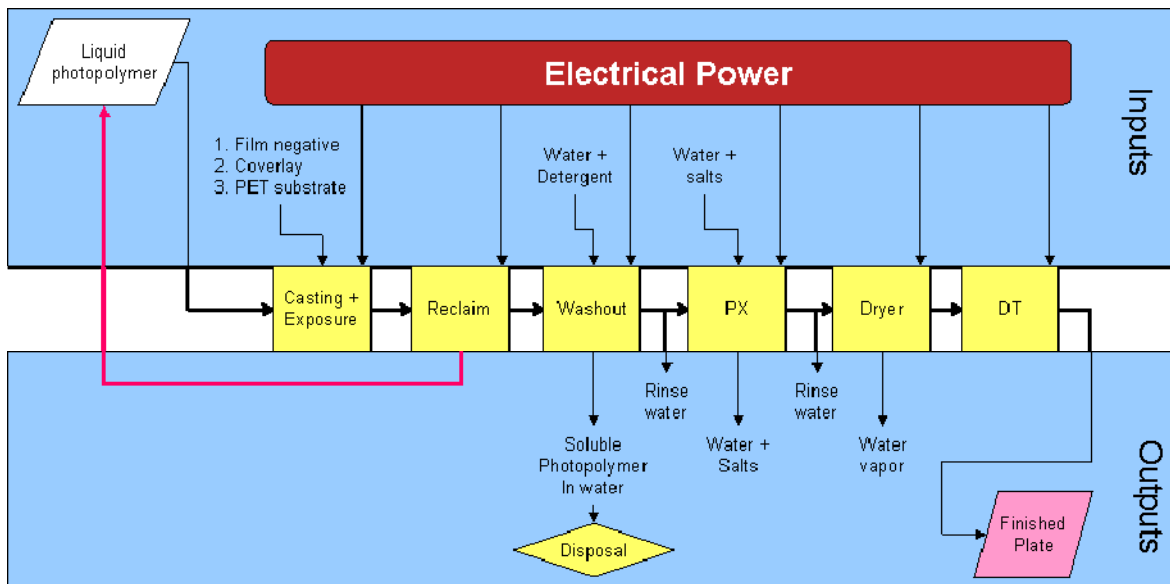

Figure 11: Liquid photopolymer platemaking sequence

The resulting ‘sandwich’ is then given UV exposure from both top and bottom to form the floor and relief image in the photopolymer. Compared to sheet photopolymer, the UV intensity of exposure lamps in liquid platemaking equipment is low, which reduces the total energy required for exposure of the photopolymer.

The next step is reclaim of the uncrosslinked photopolymer, a process which is unique to liquid photopolymer platemaking. Because the unexposed photopolymer remains in a liquid state, it can be recovered for reuse. The reclaim is accomplished either by a large planar squeegee device or by an air knife impinging on the plate surface while mounted on a drum. This reclaim step has the dual benefits of allowing high mass yields (a very high percentage of the photopolymer becomes usable plate) and reducing the amount of waste that is generated by the process overall.

After the uncrosslinked photopolymer is reclaimed, the residual liquid photopolymer left on the imaged plate is washed off by an aqueous detergent solution, followed by a brief freshwater rinse step. The plate is then subjected to post exposure (PX) exposure while immersed in a salt/water solution (the water contains salts to improve the efficiency of the PX exposure), and is then rinsed in fresh water to remove all salt from the plate surface. A short drying step is used to remove water from the plate surface (there is little water absorbed in the crosslinked polymer compared to the amount of solvent that is absorbed into sheet photopolymer, so less drying time is required). The detack exposure (DT) step is the final platemaking operation.

The outputs are a finished plate and multiple aqueous waste streams. The amount of waste photopolymer in the water is variable, depending on the reclaim method and the washout solution replenishment rate used. Depending on local regulations and facility permits, the aqueous waste can be discharged as part of an industrial wastewater stream or captured for off-site wastewater treatment, usually by filtration or flocculation.

Power consumption rates for liquid platemaking were measured on a MacDermid 52”x80” platemaking system, and total consumption was averaged over an 8 hour steady state operation making 0.250” plates with 0.125” relief. As with all platemaking types in our study, an image density (ratio of image to non-image area) of 50% was assumed. Reclaim efficiency was assumed to be 90%, a figure intermediate between the efficiencies of squeegee and air knife reclaim systems.

4 ENVIRONMENTAL FOOTPRINT CALCULATOR™ - CAPABILITIES AND FEATURES

4.1 Environmental Footprint Calculator™ Inputs

The Environmental Footprint Calculator™ allows the user to model a wide range of scenarios. The complete range of input types and values is shown in Table 1 below.

Table 1: EFC Input categories and values

Input Categories	Values
Product	Digital Sheet Plate Liquid Photopolymer
Gauge	0.045 in / 1.14 mm 0.067 in / 1.70 mm 0.125 in / 3.18 mm 0.250 in / 6.35 mm
Processing Method	Solvent Thermal Liquid (this can only be selected when Liquid Photopolymer is selected in the Product category)
Processing Location*	Canada France United Kingdom 10 regions within the United States *more locations will be added in the future
Plate length, in	Infinite
Plate width, in	Infinite
Number of Plates	Infinite

Because digital sheet plates cannot be processed by liquid washout solvents and liquid plates cannot be imaged or processed by solvent or thermal processing technology, the Environmental Footprint Calculator™ gives an error message if these infeasible scenarios are chosen. And although the tool allows the user to select any value for plate length, width, and number of plates, in practice it is easiest to work with typical plate dimensions and small numbers of plates. Attempting to model annual consumption will usually result in output values that are not easily displayed. For comparison purposes, estimated daily volumes are a convenient scale on which to perform comparisons, although the comparisons are valid down to scales as low as one square foot.

4.2 Environmental Footprint Calculator™ Outputs

After selecting the desired platemaking scenario(s) under 'Baseline Product' and the two 'Alternate Product' headings, the Environmental Footprint Calculator™ produces quantitative estimates for seven different environmental impact types:

- Energy Consumption
- Water Consumption
- Acidification of water

- Eutrophication of water
- Global Warming
- Ozone Depletion
- Smog Generation

Although this is a lot of information, MPS felt that depicting the environmental impacts as broadly and thoroughly as possible would present the best opportunity for users of the Environmental Footprint Calculator™ to evaluate each scenario by their unique set of goals and priorities. The environmental impacts of the 'Baseline Product' are given as actual values, while the environmental impacts of 'Alternate Product 1' and 'Alternate Product 2' are given as comparisons to the Baseline scenario. A brief description of each impact categories follows:

4.2.1 Energy Use

This estimates the total quantity of energy consumed during the modeled life-cycle of the product. Energy is measured in megajoules (MJ). One kilowatt-hour (kW h) is equal to 3.6 MJ. Since much of the world's energy still comes from nonrenewable sources, energy use is a chief consideration for industrial societies. In addition, the combustion of fossil fuels to create energy is a direct contributor to many other environmental impacts, including Acidification, Eutrophication, Global Warming, and Smog Generation.

4.2.2 Water Use

The total quantity of water consumed during the life-cycle of the product. With persistent drought spreading across the globe, water sources are becoming increasingly valuable, and careful water management is a top priority in many regions.

4.2.3 Acidification

Also known as 'acid rain', this is the process by which the pH of a body of water is decreased due to the entry of acidifying compounds, particularly nitric acid (HNO₃) and sulfuric acid (H₂SO₄). These substances are generated when the air pollutants sulfur dioxide (SO₂), and nitrogen oxides (NO_x) are released into the atmosphere, react with water vapor, and reach a water body through precipitation or atmospheric deposition. Acidification is detrimental to an ecosystem if the pH drops to a level at which the survivability of native organisms is impaired. In addition, a decrease in pH can cause heavy metals in surrounding geology to leach into water, potentially causing additional damage to the local environment. Nitrogen oxides are emitted during the combustion of any fossil fuel, while SO₂ chiefly comes from coal combustion.

4.2.4 Eutrophication

This is the process of nutrient enrichment [primarily phosphorus (P) and nitrogen (N)] in a body of water. Due to the increased food supply, a eutrophic body of water will commonly exhibit rampant algal growth which in turn causes in high turbidity, low dissolved oxygen levels and inhibits the penetration of sunlight into the water. All of these reduce the suitability of the water for most life forms and human recreation. Common causes of eutrophication include agricultural runoff, sewage inputs, industrial emissions, and atmospheric deposition.

4.2.5 Global Warming

This is the increase in a planet's average tropospheric (near-surface air) temperature. This can be caused by high concentrations of heat-trapping compounds - known as greenhouse gases - in the atmosphere. These include carbon dioxide (CO₂), methane (CH₄), nitrous oxide (N₂O), chlorofluorocarbons (CFC's), and stratospheric ozone (O₃). These gases are generated by fossil fuel combustion, agricultural activities, and some industrial operations.

4.2.6 Ozone Depletion

This parameter refers to the destruction of the stratospheric ozone layer which filters out ultraviolet light from the sun's radiant energy. Although useful for imaging photopolymer, human exposure to UV wavelengths can cause damage to the eyes and skin. Ozone depletion occurs when chlorinated organic compounds, mainly CFC's (chlorofluorocarbons), are emitted into the atmosphere. When activated by UV light, CFC's can release chlorine atoms that destroy ozone (O₃) molecules. The US EPA is currently phasing out the use of these compounds, but CFC's are still employed in refrigerants, air conditioning units, and some cleaning solvents.

4.2.7 Smog Generation

This is the formation of photochemical smog in the troposphere (near-surface air). A myriad of respiratory and ocular health complaints are caused by smog, including itchy eyes, sore throat, headaches, and asthma. Additionally, inhibition of the immune system can occur, potentially resulting in chronic bronchitis or emphysema. Smog forms from the reaction of nitrogen oxides (NO_x), oxygen (O₂), and volatile organic compounds (VOC's) in the presence of sunlight. Chief sources of NO_x and VOC's are combustion and products which contain solvents, respectively.

4.2.8 Savings in Comparison

In addition to the multiple impact types, the Environmental Footprint Calculator™ also converts the impact numbers into more concrete terms that make it easier to grasp the magnitude of the impacts, especially when comparing a Baseline Scenario to Alternate Products. These include:

4.2.8.1 Cars operating for 1 year

This comparison is calculated based on the total emissions of carbon dioxide (CO₂) equivalents released by the product's life-cycle from cradle to gate. The factor used for this computation is 0.520 kg CO₂ per car per year, assuming a car drives 12,500 miles annually.⁶

4.2.8.2 Gallons of oil

This comparison is calculated using the total Energy Consumption over the product's life-cycle from cradle to gate. It is assumed that one gallon of oil provides 146 MJ (40.6 kWh) of energy.⁷

4.2.8.3 Households powered for 1 day

This measure follows the Energy Consumption value under Impact Categories. The computation assumes that the average U.S. household uses 278 MJ/day (77 kWh/day), based on figures from the U.S. Energy Information Administration (2009).⁸

4.2.8.4 Laundry washloads

This reflects the Water Consumption value under Impact Categories. It is assumed that each load uses 15 gal, which is the current EPA Energy Star standard for a washing machine (EPA 2009).⁹

⁶ Office of Transportation and Air Quality. 2000. "Emission Facts: Average Annual Emissions and Fuel Consumption for Passenger Cars and Light Trucks", United States Environmental Protection Agency. Accessed 23 Dec 2009; <<http://www.epa.gov/OMS/consumer/f00013.htm>>.

⁷ Davis, S., Diegel, S., and R. Boundy. 2009. "Transportation Energy Data Book. Ed. 28." Oak Ridge National Laboratory; Doc. No. ORNL-6984. <<http://cta.ornl.gov/data/Index.shtml>>.

⁸ U.S. Energy Information Administration. 2009. Residential Energy Consumption Survey. Table US1. Total Energy Consumption, Expenditures, and Intensities, 2005. Revised January 2009. <http://www.eia.doe.gov/emeu/recs/recs2005/c&e/detailed_tables2005c&e.html>.

5 ENVIRONMENTAL FOOTPRINT CALCULATOR™ - COMPARISON OF PROCESSING TECHNOLOGIES

A few examples are presented to demonstrate its use and discuss some of the findings that result.

5.1 Thick Plate, Digital Sheet-Solvent and Liquid Photopolymer

One of the largest applications of flexography is in post-print corrugated packaging. Because of the sometimes irregular nature of corrugated substrates, this application is served best by thick, relatively soft plates. There are two ways to make such plates from photopolymer, either by solvent processing sheet plates, or by casting liquid photopolymer into thick plates. Thermal processing of sheet photopolymer is not frequently used, because the amount of blotter used to remove up to 0.125 in / 3.18 mm of photopolymer would be excessive.

For the purpose of comparison, the two scenarios were created (Table 2). The dimensions of the theoretical plate under consideration were chosen to give the equivalent of one square meter of plate material.

Table 2: Comparison of Corrugated Plate processing scenarios

	Baseline	Alternate
Product	Digital Sheet Plate	Liquid Photopolymer
Gauge	250 / 6.35	250 / 6.35
Processing Method	Solvent	Liquid Processing
Processing Location	US – East South Central	US – East South Central
Length, in	39.37	39.37
Width, in	39.37	39.37
Area, ft²	10.764 (1 m ²)	10.764 (1 m ²)
Number of Plates	1	1

The United States East South Central region was chosen to instruct the tool which region-specific power grid parameters should be used to model the impacts. The baseline scenario chosen was a 0.250 in / 6.35 mm digital sheet plate, processed by solvent. The alternative scenario was the same thickness of plate (0.250 in / 6.35 mm), but this time made from liquid photopolymer and processed in a MacDermid liquid platemaking system.

The calculated impacts for the two scenarios are shown in Table 3. The estimated impacts of the baseline scenario, which in this case is solvent processing of a 250 sheet plate, are shown for seven categories. Although figures like the MJ and mol H⁺ equivalents may not mean much at first glance, figures like 7,975 gallons of water consumed are immediately striking and make an important point about life-cycle analyses in general.

⁹ United States Environmental Protection Agency. 2009. "Laundry", as of 23 Dec 2009.; <<http://www1.eere.energy.gov/consumer/tips/laundry.html>>.

Because it is not possible to see all the processes ‘behind’ the production of the materials we use everyday, it is often difficult to understand the full impact of these materials’ production and use. But by translating the somewhat abstract category figures into more easily understood ‘Savings in Comparison’ measures such as ‘Cars operating for 1 year’, the EFC illustrates the impacts more clearly.

Table 3: Estimated environmental impacts of 1 m² solvent and liquid thick plate production scenarios

	Solvent processed plate, 0.250"/6.35 mm		Liquid photopolymer plate, 0.250"/6.35 mm		
Impact Category	Quantity	Units	Δ	Effect	
Energy Consumption:	2,227	MJ	80 %	reduction	
Water Consumption:	7,975	gal	40 %	increase	
Acidification of water:	15.57	mol H+ eq.	77 %	reduction	
Eutrophication of water:	2.7E-02	kg N eq.	11 %	reduction	
Global Warming:	70.6	kg CO2 eq.	76 %	reduction	
Ozone Depletion:	5.8E-06	kg CFC-11 eq.	26 %	reduction	
Smog Generation:	4.1E-06	kg NOx eq.	89 %	increase	
Savings in Comparison	Solvent processed plate, 0.250"/6.35 mm		Liquid photopolymer plate, 0.250"/6.35 mm		
Cars operating for 1 year:	135.7	cars	103.6	fewer	cars
Gallons of oil:	15.3	gal	12.2	fewer	gal
Households powered for 1 day:	8.0	houses	6.4	fewer	houses
Laundry washloads:	532	loads	212.9	more	loads

For ease of comparison, the alternative scenario has color coding next to it to indicate whether the alternative has a lower (green) environmental impact or a higher (red) one. The liquid platemaking process shows a pronounced advantage in most impact categories, using 80% less energy over the life-cycle studied and producing 76% less greenhouse gas. The only area where liquid platemaking shows a distinctly higher environmental impact is water consumption, where the liquid platemaking process would consume 40% more water per square meter than an equivalent solvent platemaking life-cycle. The liquid platemaking scenario also has a higher smog generation impact, but given that the estimated smog generation impact is 7.75×10^{-6} kg NO_x equivalents (that is 0.00775 grams), the overall impact in this category is relatively small.

The reasons for these differences are interesting to consider.

5.1.1 Water usage

The higher water usage through the liquid photopolymer lifecycle is not surprising, since the platemaking process itself uses water instead of an organic solvent. However, the majority of the water in the life-cycle of both the solvent sheet and the liquid photopolymer comes from the production of raw materials rather than the process itself, with only about 15% of the total water consumption estimated to come from the customer platemaking process. In other words, the liquid photopolymer process would have higher water consumption even if no water were used in platemaking.

5.1.2 Energy consumption

The dramatically lower energy consumption, greenhouse gas emission, and acidification of water estimated for the liquid photopolymer life-cycle can be assigned to two main factors:

1. The mass yield improvement due to the reclaim step, and
2. The lack of any organic solvent in the plate processing

The impact of the reclaim step in the liquid platemaking workflow is dramatic and multi-faceted. It reduces both the amount of material required to make a plate and the amount of waste created as a byproduct of the process. The combined effect is substantial.

Consider the mass efficiency of the two methods (Table 4). Quite simply put, you get more plates out of a given mass of liquid photopolymer than you can from a sheet plate. And you produce less waste, which has follow-on benefits in reducing the amount of energy used to treat the waste (e.g. by distillation) and to dispose of the waste that cannot be recovered. Some fuel value can be assigned to organic wastes for the purpose of the life-cycle assessment, but it is certainly not value that is captured by the platemaker themselves, rather it is a cost.

Table 4: Calculation of mass efficiency for liquid and sheet platemaking

	Liquid	Sheet
Plate thickness, in	0.250	0.250
Relief, in	0.125	0.125
Image density, %	50%	50%
Reclaim efficiency, %	90%	0%
Total polymer in cast/plate, in ³	45*	36
Polymer in imaged plate, in ³	29.7	29.7
Polymer reclaimed, in ³	13.77	0
Polymer waste, in ³	1.53	6.3
Mass efficiency, %	97%	83%
*the larger amount of polymer in the liquid scenario is due to the fact that the plate must be made larger than the image area in order to maintain uniform gauge over the plate's working surface.		

For In-Position Plates, which have experienced a large increase in popularity in recent years, the advantage can be *enormous* (Table 5).

Table 5: Mass efficiency comparison for In-Position liquid plates

	Liquid	Sheet
Plate thickness, in	0.250	0.250
Relief, in	0.250	0.250
Image density, %	25%	25%
Reclaim efficiency, %	90%	0%
Total polymer in cast/plate, in ³	45*	36
Polymer in imaged plate, in ³	14.4	14.4
Polymer reclaimed, in ³	27.54	0
Polymer waste, in ³	3.06	21.6
Mass efficiency, %	93%	40%
*the larger amount of polymer in the liquid scenario is due to the fact that the plate must be made larger than the image area in order to maintain uniform gauge over the plate's working surface.		

The other advantage for liquid photopolymer processing is the lack of any organic solvent in the process. Although solvent recycling processes have reached a high degree of refinement, with solvent recovery efficiencies of 90% or better, the distillation process requires energy to create the heat and vacuum used to speed distillation of relatively high-boiling flexographic plate solvents. The energy costs of distillation, the waste generated by the process, coupled with the sizable raw material impacts from production of the starting solvent, combine to add a significant amount of environmental impact to the solvent processing scenario.

5.2 Thin Plate, Digital Sheet-Solvent and Digital Sheet- Thermal

Another large application for flexography is printing on flexible packaging. The nature of this substrate, the inks required, and the graphic demands of the market combine to require a significantly different set of plate properties than the corrugated post-print example above. Plates made from liquid photopolymer are not an option available in this application because solvent-based or UV-curable inks are required to maintain good adhesion of the ink to the packaging, and liquid plates do not hold up well under these conditions. Much thinner plates are typically used because the quality requirements are much higher (typically from 120 lpi up to 175 lpi) and the substrate surface itself is much more regular.

For the purpose of comparison, two scenarios were created (Table 6). The dimensions of the theoretical plate under consideration were chosen to give the equivalent of one square meter of plate material.

Table 6: Comparison of Flexible Packaging plate processing scenarios

	Baseline	Alternate
Product	Digital Sheet Plate	Digital Sheet Plate
Gauge	045 / 1.14	045 / 1.14
Processing Method	Solvent	Thermal
Processing Location	US – East South Central	US – East South Central
Length, in	39.37	39.37
Width, in	39.37	39.37
Area, ft²	10.764 (1 m ²)	10.764 (1 m ²)
Number of Plates	1	1

Table 7 shows the output of the Environmental Footprint Calculator™. Several points are worth noting:

- The total impact of the baseline scenario is significantly lower than in the thick plate example. The energy consumption is 401 MJ vs 2227 MJ for the 250 plate, an 82% reduction. Reductions in all other impact categories are comparable. Less plate material reduces the total environmental impact, period.
- For this scenario, thermal processing shows a distinctly lower impact in virtually all categories. The 7% indicated increase in Eutrophication is small enough to be neglected, as it represents a 336 *milligram* difference in Nitrogen equivalents, which strains the quantitative precision of the results.
- Because the overall impact of both processing methods is so much lower than in the 250 plate example, most of the Savings in Comparison are far less dramatic; 3.6 cars, 0.8 gallons of oil, and 0.4 households. The water savings is more substantial, at 56.1 loads of laundry. An examination of the life-cycle data suggested that this is most likely linked to the industrial production of solvent precursors rather than the plate processing itself, since neither plate processing method uses any water.

Table 7: Estimated environmental impacts of solvent and thermally-processed thin plate production and platemaking

Impact Category	Solvent processed plate, 0.045"/1.14 mm		Thermally processed plate, 0.045"/1.14 mm	
	Quantity	Units	Δ	Effect
Energy Consumption:	401	MJ	30 %	reduction
Water Consumption:	1,436	gal	59 %	reduction
Acidification of water:	2.80	mol H+ eq.	23 %	reduction
Eutrophication of water:	4.8E-03	kg N eq.	7 %	increase
Global Warming:	12.7	kg CO2 eq.	15 %	reduction
Ozone Depletion:	1.1E-06	kg CFC-11 eq.	61 %	reduction
Smog Generation:	7.5E-07	kg NOx eq.	27 %	reduction
Savings in Comparison	Solvent processed plate, 0.045"/1.14 mm		Thermally processed plate, 0.045"/1.14 mm	
Cars operating for 1 year:	24.4	cars	3.6	fewer cars
Gallons of oil:	2.8	gal	0.8	fewer gal
Households powered for 1 day:	1.4	houses	0.4	fewer houses
Laundry washloads:	96	loads	56.1	fewer loads

A previously published environmental impact study¹⁰ made note of differences between the use of nylon and polyester blotter materials in thermal processing. Ecoform specifically examined these two material types to understand what the magnitude of this difference might be (Table 8). Intriguingly, Ecoform found the differences to be relatively minor, although polyester blotter material appeared to show a small improvement over nylon blotter material. However, the difference between blotter materials was small in comparison to either blotter material's advantage over solvent processing. As in this specific case, comparisons between LCA studies are often difficult to reconcile because of differences in the scenarios modeled by each. As MPS seeks to reduce the environmental impacts of all plate processing methodologies, it will continue to study the current processes and materials to select the best material available that meets the customer requirements that remain at the core of each technology's purpose.

Table 8: Comparison of Nylon vs Polyester blotter impacts

Scenario	Energy Consumption		Greenhouse Gas Emission	
	MJ/ft ²	Delta from solvent, %	kg CO ₂ eq/ft ²	Delta from solvent, %
Thermal, nylon blotter	58	-29%	2.2	-15%
Thermal, polyester blotter	55	-33%	2.1	-19%
Solvent	82	0%	2.6	0%

¹⁰ DuPont Engineering and Research Technology 2008. "Life cycle assessment: flexographic and rotogravure printing comparison & flexographic plate imaging technologies." E.I. Du Pont de Nemours and Company. http://www2.dupont.com/Cyrel_Sustainability/en_GB/lca_request.html

5.3 Thin Plate, Digital Sheet-Thermal and Liquid Photopolymer

Finally, there is a tremendous amount of water-based ink used in printing paper substrates other than corrugated, and liquid photopolymer plates are also extensively used in the Multi-wall Bag and Folding Carton market segments. With lower substrate thickness and surface variation, these applications are able to use thinner (0.067 in / 1.70 mm), harder (50 durometer) plates to achieve resolutions of 120 lpi and 2% dots. Three platemaking relevant scenarios are shown in Table 9.

Table 9: Comparison of Multi-wall Bag or Folding Carton plate processing scenarios

	Baseline	Alternate 1	Alternate 2
Product	Digital Sheet Plate	Digital Sheet Plate	Liquid Photopolymer
Gauge	067 / 1.70	067 / 1.70	067 / 1.70
Processing Method	Solvent	Thermal	Liquid Processing
Processing Location	US – East South Central	US – East South Central	US – East South Central
Length, in	39.37	39.37	39.37
Width, in	39.37	39.37	39.37
Area, ft²	10.764 (1 m ²)	10.764 (1 m ²)	10.764 (1 m ²)
Number of Plates	1	1	1

After reading the preceding scenarios, the results are as expected, with thermal showing some reduction in environmental impact and liquid photopolymer showing a major reduction in most categories, albeit with higher water utilization (Table 10). The thinner plates show less impact overall

Table 10: Estimated environmental impact of platemaking options for water-based ink printing on paper

	Solvent processed digital plate, 0.067"/1.70 mm		Thermally processed digital plate, 0.067"/1.70 mm		Liquid photopolymer plate, 0.067"/1.70 mm	
Impact Category	Quantity	Units	Δ	Effect	Δ	Effect
Energy Consumption:	597	MJ	30 %	reduction	80 %	reduction
Water Consumption:	2,137	gal	59 %	reduction	40 %	increase
Acidification of water:	4.17	mol H+ eq.	23 %	reduction	77 %	reduction
Eutrophication of water:	7.1E-03	kg N eq.	7 %	increase	11 %	reduction
Global Warming:	18.9	kg CO2 eq.	15 %	reduction	76 %	reduction
Ozone Depletion:	1.6E-06	kg CFC-11 eq.	61 %	reduction	26 %	reduction
Smog Generation:	1.1E-06	kg NOx eq.	27 %	reduction	89 %	increase
Savings in Comparison	Solvent processed digital plate, 0.067"/1.70 mm		Thermally processed digital plate, 0.067"/1.70 mm		Liquid photopolymer plate, 0.067"/1.70 mm	
Cars operating for 1 year:	36.4	cars	5.4	fewer	27.8	fewer
Gallons of oil:	4.1	gal	1.2	fewer	3.3	fewer
Households powered for 1 day:	2.1	houses	0.6	fewer	1.7	fewer
Laundry washloads:	142	loads	83.5	fewer	57.1	more

6 SUMMARY

6.1 General

MPS' analysis of the environmental impact of solvent, thermal, and liquid platemaking options found that environmental impact decreased in the order:

Solvent > Thermal > Liquid

This finding held under all scenarios studied. The advantage was especially pronounced for thick plates, where thermal processing is not currently practiced, and where the mass yield advantage of the liquid reclaim step gives a profound advantage to liquid platemaking technology.

Thermal plate processing also appears to offer a lower environmental impact compared to solvent processing. Although solvent recycling has become a very efficient industrial process over the years, the use of solvent inevitably expands the environmental impact of platemaking, simply by its presence.

Lastly, although solvent platemaking had the greatest environmental impact in all the scenarios shown, it is an option that has many positive attributes and which still deserves serious consideration from all those in the flexographic industry.

6.2 Future Work

Life-Cycle Assessment is a relatively new and rapidly developing discipline. In particular, the datasets for the life-cycle assessment of specialty chemicals are in their infancy, which necessitated some generalizations and assumptions about raw materials. Although validated against best practices in LCA studies, such approximations are never satisfying to the technically oriented. As more industries demand accurate and more far-reaching life-cycle data, MPS expects to incorporate all improved data in its analyses, and will be updating the Environmental Footprint Calculator™ at regular intervals so that the best decision-making information will be available to its customers.